

CURRENT OWNER		TOPO	UTILITIES	STRT / ROAD	LOCATION	CURRENT ASSESSMENT				
PHIPPEN MICHAEL C & HAGAN SEA MICHAEL CHARLES PHIPPEN LIV TR 47 SUMMER ST DUXBURY MA 02332			02 Water	0 Arterial	0 Average	Description	Code	Appraised	Assessed	905 DUXBURY, MA VISION
			08 No Sewer	0 Paved	0 Average	RESIDNTL	1010	315,200	315,200	
		SUPPLEMENTAL DATA				RES LAND	1010	367,700	367,700	
		Alt Prcl ID Scnd Home Tax Class T Tot Fin Area 1732 Total Acres .92 Chapter Lan GIS ID F_864358_2836789			Cyclical 4 Exemption W District Res Exem Assoc Pid#	RESIDNTL	1010	3,400	3,400	
						Total	686,300	686,300		

RECORD OF OWNERSHIP		BK-VOL/PAGE	SALE DATE	Q/U	V/I	SALE PRICE	VC	PREVIOUS ASSESSMENTS (HISTORY)				
PHIPPEN MICHAEL C & HAGAN SEAN A	59738 315	03-03-2025	U	I	1	1A	Year	Code	Assessed	Year	Code	Assessed
PHIPPEN MICHAEL CHARLES	58583 285	01-05-2024	Q	I	675,000	00	2026	1010	315,200	2025	1010	301,200
CLANCY PATRICK	50086 0348	07-25-2018	Q	I	500,000	00		1010	367,700		1010	350,400
SARVIS STEVEN GLEN & SARVIS DEBR	5644 0461	05-18-1984	Q	I	106,000	00		1010	3,400		1010	3,400
							Total	686,300	Total	655,000	Total	648,000

EXEMPTIONS			OTHER ASSESSMENTS					
Year	Code	Description	Amount	Code	Description	Number	Amount	Comm Int
		Total	0.00					

ASSESSING NEIGHBORHOOD				
Nbhd	Nbhd Name	B	Tracing	Batch
0050				

BUILDING PERMIT RECORD										VISIT / CHANGE HISTORY					
Permit Id	Issue Date	Type	Description	Amount	Insp Date	% Comp	Date Comp	Comments		Date	Id	Type	Is	Cd	Purpose/Result
2015-287	12-01-2015	MS	Miscellaneous	17,015		100		STRIP & REROOF		11-30-2018	SJD	9		01	Measure - No Entry
2015-284	11-30-2015	MN	Maintenance	2,001		100		REPLACE 2 DOORS		04-12-2013	VGS			20	Field Review
2015-228	10-01-2015	MN	Maintenance	14,615		100		STRIP & REROOF		08-22-2007	BSB		1	00	Measure & Listed
2013-170	09-17-2013	MN	Maintenance	1,484		100		REPLACE 1 WINDOW							
152	09-30-2010	MN	Maintenance	2,200		100		1 DOOR							

LAND LINE VALUATION SECTION															
B	Use Code	Description	Zone	Land Type	Land Units	Unit Price	Size Adj	Site Index	Cond.	Nbhd.	Nbhd. Adj	Notes	Location Adjustment	Adj Unit P	Land Value
1	1010	Single Family	RC	Primary	40,050 SF	9.18	1.00000	5	1.00	0050	1.000		1.0000	9.18	367,700
Total Card Land Units					0.92 AC	Parcel Total Land Area					0.92	Total Land Value			367,700

CONSTRUCTION DETAIL			CONSTRUCTION DETAIL (CONTINUED)		
Element	Cd	Description	Element	Cd	Description
Style	00	Gambrel	Bsmt Area	816	
Model	01	Residential	Bsmt Type	04	
Grade	04	Above Ave	Unfin Area	0.00	Full
Stories	1.9				
Occupancy	1				
Exterior Wall 1	14	Wood Shingle			
Exterior Wall 2					
Roof Structure	07	Gambrel			
Roof Cover	03	Asphalt			
Interior Wall 1	05	Drywall			
Interior Wall 2					
Interior Floor 1	12	Hardwood			
Interior Floor 2					
Heat Fuel	03	Gas			
Heat Type	05	Hot Water			
AC Type	01	None			
Bedrooms	3				
Full Baths	1				
Half Baths	1				
Extra Fixtures	0				
Total Rooms	6				
Bath Style	02	Average			
Kitchen Style	02	Average			
Extra Kitchens	0				
Fireplaces	1				
Extra Openings	0				
Gas Fireplaces	0				
Sq Ft Fin Bsmt	0				
FBM Quality					
Foundation	06	Poured Conc			
Bsmt Garage	0				
Bsmt Area	816				

CONDO DATA			
Parcel Id		C	Ownr
		B	S
Adjust Type	Code	Description	Factor%
Condo Flr			
Condo Unit			

COST / MARKET VALUATION		
		397,334
Net Other Adj		12,075
Replace Cost		409,409
Year Built		1972
Effective Year Built		1998
Depreciation Code		G
Remodel Rating		
Year Remodeled		
Depreciation %		23
Functional Obsol		
External Obsol		
Trend Factor		1.000
Condition		
Condition %		
Percent Good		77
Cns Sect Rcnld		315,200
Dep % Ovr		
Dep Ovr Comment		
Misc Imp Ovr		
Misc Imp Ovr Comment		
Cost to Cure Ovr		
Cost to Cure Ovr Comment		

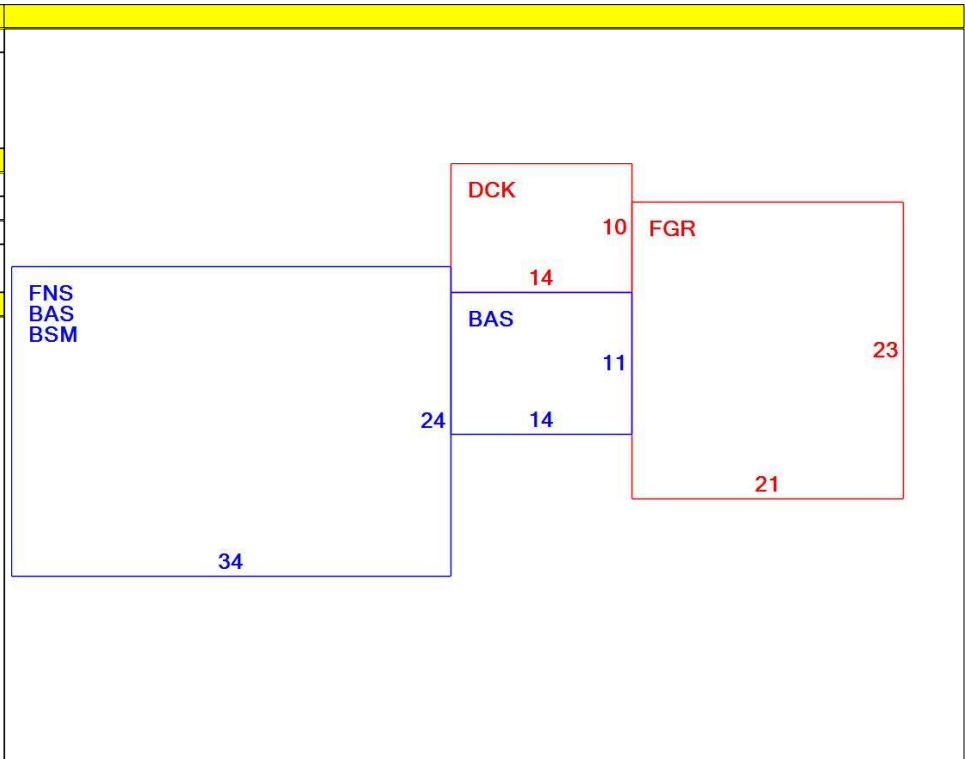

OB - OUTBUILDING & YARD ITEMS(L) / XF - BUILDING EXTRA FEATURES(B)										
Code	Description	L/B	Units	Unit Price	Yr Blt	Cond. Cd	% Gd	Grade	Grade Adj.	Appr. Value
PTO	Patio	L	324	15.00	2005	A	70	C	1.00	3,400

BUILDING SUB-AREA SUMMARY SECTION						
Code	Description	Living Area	Floor Area	Eff Area	Unit Cost	Undeprec Value
BAS	First Floor	970	970	970	191.58	185,831
BSM	Basement	0	816	163	38.27	31,227
DCK	Deck	0	140	14	19.16	2,682
FGR	Garage	0	483	193	76.55	36,975
FNS	Finished 90% Story	734	816	734	172.33	140,619
Ttl Gross Liv / Lease Area		1,704	3,225	2,074		397,334

